

UTILITY ACCOMMODATION POLICY



Engineering Services
February 15, 2024

TABLE OF CONTENTS

PART 1 - GENERAL POLICY

A. Policy Application	1-1
B. Utility License Agreement Requirements	1-3
C. Construction	1-6
D. Safety	1-7
E. Material Storage	1-8
F. Call Before You Dig!	1-8
G. Maintenance and Servicing Utilities	1-8
H. Preservation, Restoration and Cleanup	1-9
I. Protection of Vegetation	1-10

PART 2 - UTILITIES PARALLELING RAILROAD PROPERTY

A. General Provisions	2-1
B. Overhead Installations	2-1
C. Underground Installations	2-3
D. Attachment to Bridges and Other Structures	2-5
E. Drains for Steep Slopes (Tight Lines)	2-5

PART 3 - UTILITIES PERPENDICULAR TO RAILROAD PROPERTY

A. General Provisions	3-1
B. Overhead Installations	3-1
C. Underground Installations	3-3

APPENDIX

A. Overhead Installations	
1. Plan/Profile Example	A-1
2. Loading Districts Map	A-2
B. Underground Installations	
1. Plan/Profile Example	A-3
2. Jack_and_Bore, HDD Examples	A-4
3. HDD Standards	A-5
C. Temporary Shoring Review Comments Sheet	A-6
D. Retirement/Removal of Pipelines	A-7
E. Drains For Steep Slopes (Tight Lines)	A-8
F. Definition of Terms	A-9



PART 1
GENERAL POLICY

I. PART 1 - GENERAL POLICY

A. Policy Application

1. Purpose

This policy is to prescribe the accommodation, location and method of installation, adjustments, removal, relocation, and maintenance of utility facilities within the property of BNSF. The policy was developed in the interest of safety, protection, utilization, and future development of BNSF with due consideration given to public and private service afforded by adequate and economical utility installations.

2. Application

The policy concerning utility accommodations shall apply to all:

- a. New utility installations
- b. Additions to existing utility installations
- c. Adjustment and relocation of utilities
- d. Existing or planned utility installations for which agreements with BNSF were entered prior to the date of the adoption of this policy.
- e. Existing utility installations that do not meet the current license requirements may remain at the discretion of **BNSF**.

Various types of utility lines not specifically discussed herein shall be considered within the provisions of this policy. It shall be the general practice to consider all lines carrying caustic, flammable, or explosive materials under the provisions for high-pressure gas and liquid fuel lines.

3. Scope

Utilities include lines, facilities, and systems for producing, transmitting, or distributing communications, power, electricity, light, heat, gas, oil, crude products, water, steam, waste, storm water and other similar commodities which are privately, publicly, or cooperatively owned and which serve directly or indirectly the public or any part thereof.

A Utility Agreement License allowing a Utility Owner the privilege of placing its facilities in or on railroad property does not constitute permanent right for such usage. Whether required by BNSF or not, any removal, remodeling, maintenance, or relocation of the facilities, will be accomplished promptly by the Utility Owner at no cost to BNSF.

4. Exceptions

Exceptions to any design, location or methods of installation provisions contained in this policy must be authorized by BNSF. Requests for exceptions will be considered only where it is shown that extreme hardship and/or unusual conditions provide justification and where alternate measures can be prescribed in keeping with the intent of this policy. All requests for exceptions shall be fully documented by identifying what variance is needed, and why, including design data, cost comparisons and other pertinent information. Please Note: BNSF authorization may cause additional processing time for the application.

5. Liability

The Utility Owner, its successor(s), or assignees shall assume all risk and liability for accidents and damages that may occur to persons or property on account of this work, and shall indemnify and hold BNSF harmless from any and all costs, liabilities, expenses, suits, judgments or damages to persons or property, or claims of any nature whatsoever, arising out of or in connection with the permit, or the operation and performance thereunder by the utility, its agents, employees or subcontractors. In this regard, it is further understood and agreed that the utility may be required to obtain insurance coverage as determined by BNSF.

The Utility Owner agrees that if liability insurance is required, it will file with the designated office, prior to granting of the license, "Certificates of Insurance" or other evidence to show that the appropriate insurance is carried.

Insurance, as may be required, shall be maintained in force until the final release of the Utility Owner by BNSF from all obligations under the terms of the license. The insurance contract shall cover claims for such length of time as law permits said claims. The insurance document shall include a clause requiring the insurer to notify BNSF at least ten (10) days in advance of any cancellation or change in insurance contracts.

The Utility Owner is responsible for any subcontractor to be knowledgeable of this policy and require all work to be conducted in compliance with it. Subcontractors must carry a liability insurance policy unless the subcontractor is covered by the Utility Owner's insurance.

6. Replacement/Relocation of Facility

Replacement or relocation of an existing facility with the same facilities or facilities of a different type, or design, is to be considered as a new utility installation and all work shall adhere to this policy. This includes such things as extension of an existing casing, replacing with a larger / smaller pipe diameter, etc. When replacing an underground pipeline or conduit, an abandonment plan must be included in the general plans.

7. Change in Ownership

It is the Utility Owner's responsibility to inform BNSF, in writing, of any name, ownership or address changes.

8. Non-compliance

Non-compliance with any terms of this Utility Accommodation Policy or Utility License Agreements may be considered as cause for discontinuance of construction or operations until compliance is assured. Continued non-compliance will result in the revocation of the license. The cost of any work required by BNSF in the removal of non-complying construction will be assessed against the Utility Owner.

9. Discharge of Waste Material

Applications for a Utility License Agreement for the installation of utility facilities which will discharge materials into the nation's waters, must comply with all applicable requirements of the Corps of Engineers, and other federal, state, or local environmental protection agencies. Identification of applicable requirements and administration of compliance procedures are the responsibility of the Utility Owner.

B. Utility License Agreement Requirements

1. General

Utility License Agreements are required when utility facilities are installed, relocated, removed, or maintained along or across all BNSF property.

If liability insurance is required, then evidence of adequate liability insurance is to be on file with BNSF for each agreement prior to any construction activity.

2. Applications

Approved requests to install, maintain, relocate, or remove a utility within the property of BNSF shall be authorized by a Utility License Agreement. All applications for utility license agreements along with plans for the proposed installation shall be submitted to BNSF and approved before construction has commenced. Any exceptions to this policy will require the completion of an exception form and may cause additional processing time.

3. Plans and Approvals

a. Approval of plans and application forms is required for all installations of utilities prior to initiation of work on railroad property. A Professional Engineer's seal is required for plans detailing:

- Pipelines installed within Shoring Zone A as shown in Figure 1, Pg 3-4, with an outside diameter greater than 8 inches; or

- Temporary shoring on the right-of-way; or
 - Overhead pipeline bridge crossings; or
 - Overhead electric transmission lines greater than 12.5kV.
- b. If surveying, or environmental/geotechnical study on BNSF right-of-way is necessary for the completion of an application, a “Temporary Occupancy Permit” must be executed and referenced. Additionally, a BNSF qualified flagman will be required when working within twenty-five (25) feet of the track.
4. License Procedures:
- a. Submit applications online by going to <https://bnsf.railpermitting.com> and complete the application process and pay the application fee.
 - b. Upon receipt of the application, an email confirmation will be forwarded acknowledging receipt and advising of the Permit tracking number that has been assigned.
 - c. Agreements will be required for all encroachments on railroad property.
 - d. Generally, agreement-processing time will be thirty to sixty days or longer depending on plan revisions, the complexity of the project(s) and/or permit redlines. Please allow sufficient lead-time for document handling prior to desired construction date. Before construction begins, agreements must be executed by Utility Owner and returned. Verbal authorizations will not be granted or permitted. All work must be set up, in advance, with the BNSF Utility Coordinator to coordinate the Construction Inspector and flagger.
 - e. License fees must be paid online through <https://bnsf.railpermitting.com> for the agreement to be fully executed.
5. Location
- a. Utility lines shall be located to avoid, or minimize, the need for adjustments for future railroad improvements and to permit access to the utility lines for their maintenance with minimum interference to railroad traffic.
 - b. Pipelines shall be installed under tracks by boring, jacking, or in some cases, open trenching (must be pre-approved by BNSF). **WATER JETTING IS NOT PERMITTED.**
 - c. Where practical, pipelines carrying liquefied petroleum gas shall cross the railway where the tracks are carried on an embankment.
 - d. All high-pressure pipelines (greater than 60-psi internal pressure), except those in public roads, shall be prominently marked and maintained at the property line (on both sides of the track for under crossings) by signs which state the utility owner, size of the

line and its depth as well as a 24-hour emergency contact number, which will be maintained if the utility is in service. These signs will be inspected annually and replaced should they become unreadable.

Example:

CAUTION: Bob's Gas Service, 1-800-123-4567, 30-inch diameter high-pressure Gas main 7 feet deep.

6. Design Considerations

- a. The design of any utility installation will be the responsibility of the Utility Owner. Any proposed installation within the railroad property must be reviewed and approved by the railroad regarding location and the method of construction, installation, and replacement. This includes the measures to be taken to preserve the safety and flow of rail traffic, insure it does not obstruct right of way access for BNSF, structural integrity of the roadway or structure, ease of maintenance and the integrity of the utility facility. Utility installations, on, over or under BNSF property shall conform with the requirements contained herein, or the appropriate requirements outlined in the following, whichever is deemed most safe:
 - (1) Safety Rules for the Installation and Maintenance of Electric Supply and Communication Lines-National Electric Safety Code.
 - (2) Title 49 C.F.R. Part 192, Transportation of Natural and Other Gas by Pipeline: Minimum Federal Safety Standards.
 - (3) Title 49 C.F.R. Part 195, Transportation of Hazardous Liquids by Pipelines.
 - (4) American Society for Testing and Materials (ASTM) Specifications - latest edition.
 - (5) Manual on Uniform Traffic Control Devices for Streets and Highways (MUTCD) - latest edition, published by the Federal Highway Administration (FHWA) of the United States Department of Transportation (USDOT).
 - (6) Rules and Regulations for Public Water Systems - latest edition, published by the appropriate State Health Department.
 - (7) Occupational Safety and Health Administration (OSHA) Title 29 C.F.R. Standard 1926 – Safety and Health Regulations for Construction.
- b. All utility installations on, over or under BNSF property shall be of durable materials designed for long service life and relatively free from routine servicing and maintenance requirements. Conformance with current applicable material specifications and codes is mandatory.

- c. References given to any manual, publication or specification are intended to be the most current edition. If a conflict occurs between any publication and this manual, the specification deemed most safe will be used.
- d. Geo-technical Study is required for pipeline installations crossing under the tracks greater than twenty-six (26) inches in diameter, and less than twelve (12) feet below base of rail, using a method other than jack-and-bore. Refer to part B.3.b., found on page 1-4 of this document for requirements of the study and review.
- e. Temporary Shoring is required for all excavations on BNSF right of way, including boring pits, and design plans are subject to review and approval by BNSF. Refer to Appendix for the review sheet that lists items to be included in the Temporary Shoring Plans.

C. Construction

1. Coordination with the Construction Inspector and/or flagging company, along with any required deposits, will be arranged prior to any construction on BNSF property.
2. The execution of the work on railroad property shall be subject to the inspection and direction of the Construction Inspector.
3. A representative of BNSF Signal Department must be present during installation if railroad signals are in the vicinity of the proposed construction.
4. Any dirt that is excavated for pits, poles, bores, etc. will remain on BNSF property. BNSF Environmental will be consulted before any soils are removed from BNSF property which can be coordinated through the Construction Inspector.
5. Spills, of any quantity, must be reported to the Service Interruption Desk. This can be coordinated through the Construction Inspector.
6. A plan to monitor for settlement or heave of the railroad facilities must be developed, accepted, and implemented to assure no adverse effect on the railroad's activities because of the work. The plan should detail the types of settlement points that will be installed and monitored as well as the frequency of monitoring and the reporting mechanism. Because the track will tend to bridge over the area affected by the drilling / boring / trenching operation, the monitoring plan should include checking for settlement or heave at a depth below the track. Surveying of the monitoring points may be accomplished by traditional means or an automated system. A baseline survey should be conducted before the start of construction.

Most settlement plans include a two-step process against which the monitoring data is measured. The alert threshold limit is the value intended to bring attention to the movement so that it can be managed without reaching the maximum level. The maximum level is the highest allowable movement value and should be less than the value that could result in damage to the railroad facilities.

Reaching the threshold limit may trigger the following actions:

- (1) Discussion of the data and its implications
- (2) Increase in the frequency of monitoring.
- (3) Independent confirmation of the monitoring data
- (4) A review of construction methods to determine if changes are required to mitigate further movement.

Reaching the maximum limit may trigger the following actions:

- (1) Immediate stoppage of construction and notification to the railroad
- (2) Independent confirmation of movement
- (3) Review of construction methods and implementation of contingency plans, if needed
- (4) Re-evaluation of critical structures in the area and installation of additional monitoring devices if needed.

Alert threshold values are from $\frac{1}{4}$ to $\frac{3}{4}$ inch with maximum values from $\frac{1}{2}$ to 1 inch.

7. The utility installation is not considered complete until as-built drawings are submitted and verified as correct by the Construction Inspector.

D. Safety

The BNSF Contractor orientation course must be completed by all workers prior to entering BNSF property. It is the contractor's responsibility to implement a safety program for its employees. Training materials are available on the web site: www.bnsfcontractor.com. The contractor must comply with all federal, state, and local safety regulations.

1. Construction Inspector

- a. A Construction Inspector shall be required for all utility installations, and projects involving excavation, grading, construction and building demolition on BNSF right of way, with the total cost borne by the Utility Owner.
- b. The Construction Inspector will be notified of the construction monitoring methods and frequency to be used.
- c. Once construction is complete, the Utility Owner will provide the Construction Inspector with as-built drawings noting any changes from the original specifications approved when the permit was issued. These as-built drawings must be verified by the Construction Inspector and submitted to BNSF for their records.

2. Flagging

- a. When work is performed within BNSF right-of-way, railroad flagging and construction inspection will be required.

- b. Railroad flagging will be required:
 - i. During the period of construction when it is necessary for the Contractor to operate equipment in the vicinity of, under, or over, BNSF property which may endanger railroad operations, or
 - ii. Two or more railroad flagmen may be required at other times that the Railway Company's sole discretion shall deem necessary.
- c. Flagging services shall be performed by a BNSF qualified flagger and the total cost borne by the Utility Owner.
- d. The Utility Owner will be billed monthly, or as required to maintain required services, at a rate to be determined by BNSF to include labor and associated costs plus any expenses incurred for inspection and/or flagging services.
- e. A written request for inspection and flagging services will be required at least two (2) weeks prior to the time when such services are needed. This request is made to the BNSF scheduling agent, as noted in executed agreement.

E. Material Storage

Storage of materials, parking of equipment and vehicles when not being used in actual utility work, will not be permitted on railroad property without an executed temporary easement.

F. Call Before You Dig!

Call 811 to schedule a utility locate and call 1-800-533-2891 (for BNSF Telecom) and 800-832-5452 (For BNSF Signal) to arrange for a BNSF underground cable locate. BNSF form "Underground Cable Location & Acknowledgement" will be completed by a BNSF representative with a copy provided to the contractor. The contractor must always have this completed form available for review at the job site.

G. Maintenance and Servicing Utilities

- 1. Utility Owner's Responsibility
 - a. Maintenance of the utility is the responsibility of the Utility Owner.
 - b. Maintenance must be performed to keep the facility in an as-constructed condition, and in a good state of repair in accordance with the requirements of Federal, State and Local laws, regulatory standards, and utility codes.
 - c. It is the Utility Owner's responsibility to replace and stabilize all earth cover and vegetation when it has eroded over an underground utility facility where such erosion is due to, or caused by, the placement or existence of the underground utility facility.

- d. The Utility Owner shall be responsible for any settlement of backfill, fills, and embankments that may occur.

2. Emergency Maintenance

- a. Emergency maintenance of utilities located on railroad property is permissible without obtaining a Utility License Agreement if an emergency exists that is dangerous to the life, safety, or welfare of the public and which requires immediate repair. The Utility Owner shall take all necessary and reasonable safety measures to protect the public and the railroad.
- b. The Utility Owner, in such an event, will advise the Railway as soon as possible. Damage to the right-of-way and facilities will be restored to its original condition. A Utility License Agreement should be requested by the Utility Owner within the second working day provided the work is not covered under any previously granted license. Flagging requirements described earlier apply in all situations.

H. Preservation, Restoration and Cleanup

1. Disturbed Areas

- a. Areas of railroad property disturbed by the installation, maintenance, removal, and relocation of utilities shall be kept to a minimum.
- b. After review and concurrence from the BNSF Environmental Group, disturbed areas shall be returned to normal grade and elevation, with compaction of backfill material and all excess or undesirable material removed by the Utility Owner. The Utility Owner shall replace destroyed vegetation by sodding, or seeding, fertilizing, and mulching, or a combination thereof.
- c. The Utility Owner shall provide protection against erosion in disturbed areas that are subject to erosion. Such protection may be in the form of rock riprap, wash checks, hay or straw cover, or other material that is approved and does not interfere with railroad maintenance.

2. Drainage Facilities

- a. Care shall be taken to avoid disturbing existing drainage facilities. Underground utility facilities shall be bedded with pervious material and outlets provided for entrapped water. Underdrains should be provided where necessary.
- b. Grades shall be sloped away from the track roadbed and towards the ditch, when possible, with the goal of no standing water on railroad property.

3. Cleanup

- a. Unused material or debris shall be removed from the work site area. At the end of every construction day, construction equipment and materials shall be removed as far from the operating railroad tracks as possible (minimum twenty-five (25) feet from centerline). All machines will be disabled when not in use to prevent unauthorized operation. No equipment or materials will be allowed to be staged on BNSF property without an executed temporary easement.

I. Protection of Vegetation

1. Trimming, Clearing or Removal of Vegetation

- a. Consistent with the preservation of planted vegetation, consideration will be given to Utility Owners for the necessary trimming, clearing or removal of vegetation to provide adequate clearance of overhead wires. Such work will be done in accordance with established practices and standards; however, approval will not be granted for wasteful or wanton trimming, or removal to provide easy solutions to a difficult situation.
- b. No trees, shrubs, bushes, vines, or ground cover on railroad property shall be sprayed, trimmed, cut down, rooted up, removed, or mutilated in any manner unless a permit is granted by BNSF to do such work.

2. Chemical Brush Control

- a. Spraying brush and seedling tree growth to prevent re-sprouting may be permitted, and when permitted, shall be carried out with extreme caution and careful performance. The Utility Owner shall be responsible for the performance of their employees or contractors in the application of brush control with methods and proposed chemicals approved by BNSF Environmental Department.
- b. All spraying shall be done by an herbicide applicator that is licensed in the state where the work is to be performed.

- c. Permit applications for spraying shall list the kinds of chemical weed and brush killers that will be used. When liability insurance is required, it shall be provided by the herbicide applicator, or be insured under the liability insurance of the Utility Owner.
- d. Plants over five (5) feet in height should not be sprayed for control. Brush over five (5) feet in height, which is to be removed, should be cut and the stumps treated to prevent growth. Shrubbery type growth such as dogwood, sumac, redbud, plum, etc., should not be sprayed as a rule. Steep slopes, where brushy growth is a major factor in preventing erosion, should not be sprayed.

3. Tree Pruning

- a. Tree pruning on railroad property for utility lines will utilize the best horticultural practices. All cut branches, dead limbs, etc., shall be removed. Such materials shall not be burned or disposed of on railroad property unless permission is granted by the Utility License Agreement.
- b. Should burning be permitted, the Utility Owner will be held liable for any damage to grass, crops, native shrubs, and trees arising from careless burning of such brush.
- c. All limbs trimmed shall be removed with a clean cut and all limb scars over one (1) inch in diameter shall be treated with appropriate tree paint.



PART 2

UTILITIES PARALLELING

RAILROAD PROPERTY

PART 2 - UTILITIES PARALLELING RAILROAD PROPERTY

A. General Provisions

This section of the policy applies to all public and private utilities, including electric power, telephone, fiber optics, telegraph, cable television, water, gas, oil, petroleum products, steam, chemicals, sewage, drainage, irrigation, and similar lines that are located, adjusted, or relocated within the property under the jurisdiction of BNSF, but not actually crossing the tracks. Such utilities may involve underground, surface, or overhead facilities.

Any such utility line will be considered a parallel line and is to be located on a uniform alignment, within ten (10) feet or less of the property line and a minimum of forty (40) feet from centerline of track to provide a safe environment and to preserve space for future railroad improvements or other utility installations. BNSF Engineering must approve any installation over one mile.

Utilities will be located to provide a safe environment and shall conform to the current “National Electrical Safety Code,” “American Waterworks Association Specifications,” “Federal Pipeline Safety Regulations,” and “The American Railway Engineering and Maintenance Association (AREMA) recommendations.” Where laws or orders of public authority prescribe a higher degree of protection, then the higher degree of protection prescribed shall supersede the provisions of this manual.

Approval of plans and application forms is required for all installations of utilities prior to initiation of work on railroad property. A Professional Engineer’s seal is required for plans detailing:

- Pipelines installed within Shoring Zone A as shown in Figure 1, Pg 3-4, with an outside diameter greater than 8 inches; or
- Temporary shoring on the right-of-way; or
- Overhead pipeline bridge crossings; or
- Overhead electric transmission lines greater than 12.5 kV.

B. Overhead Installations

1. Must comply with all requirements of Part 1 – General Policy of this manual.
2. The design of all utility installations will be the responsibility of the Utility owner. Plans shall be drawn to scale showing the relationship of the proposed utility line to the railroad tracks, the angle of crossing, location of valves and vents, the railroad mile post and engineering station, railroad property lines and general layout of tracks and other railroad facilities. The plans should include a cross-section (or sections) from the field survey that will show utility placement in relation to actual profile of ground and tracks.

3. Applications can be submitted along with plans detailing location, both horizontal and vertical, of proposed utility with dimensions from track and/or right-of-way boundaries at <https://bnsf.railpermitting.com>.
4. A minimum of four (4) feet clearance is required above existing signal and communication lines.
5. Pole height and distance from centerline of nearest track must be shown on an aerial exhibit and included with the application along with a profile that includes the wire attachment height and anticipated maximum sag.

Poles must be located a minimum of fifty (50) feet out from the centerline of railroad mainline, branch and running tracks, CTC sidings, and heavy tonnage spurs. Pole locations adjacent to industry tracks; must provide at least a ten (10) foot clearance from the centerline of track, when measured at right angles. If located adjacent to curved track, then said clearance must be increased at a rate of one and one-half (1-1/2) inches per degree of curved track.

Regardless of the voltage, un-guyed poles shall be located a minimum distance from the centerline of any track, equal to the height of the pole above the ground-line plus ten (10) feet. If guying is required, the guys shall be placed in such a manner as to keep the pole from leaning/falling in the direction of the tracks.

Poles (including steel poles) must be located a minimum distance from railroad signal and communication lines equal to the height of the pole above the ground-line or else be guyed at right angles to the lines. High voltage towers (34.5 kV and higher) must be located off railroad right of way. All poles will contain a sign stating the utility owner, voltage of the lines and a 24-hour emergency contact phone number that will be maintained if the utility is in service. The utility owner will be responsible to de-energize, sleeve, etc. in the event a BNSF emergency requires access.

For proposed electrical lines paralleling tracks, BNSF may request that an inductive coordination study be performed at the expense of the utility owner. Inductive interference from certain lines has the potential to disrupt the signal system in the track causing failures in the track signals and highway grade crossing warning devices. Generally, if the proposed electrical line exceeds 12.5 kV *and* runs parallel to the track for at least 1,000 feet, a study will be required. A study will be required if a new sub-station is to be located within 1,000 feet of the track. The General Director of Signals will determine the need for a study on a case-by-case basis.

6. Abandonment/Removal/Replacement of Facilities

- Upon termination of license the utility needs to be removed from BNSF property.
- Abandoned or replaced poles shall be removed from BNSF property or cut off to a depth at least six (6) feet below ground; and the hole filled with BNSF approved material and compacted to surrounding ground level.

- All metal such as rebar, cable, anchor systems, and strain relief must be removed and disposed of in accordance with local, state and federal regulations.
- An abandonment or replacement plan must be included in the general plans.

C. Underground Installations

1. Must comply with all requirements of Part 1 – General Policy of this manual.
2. The design of all utility installations will be the responsibility of the Utility owner. Plans shall be drawn to scale showing the relationship of the proposed utility line to the railroad tracks, the angle of crossing, location of valves and vents, the railroad mile post and engineering station, railroad property lines and general layout of tracks and other railroad facilities. The plans should include a cross-section (or sections) from the field survey that will show utility placement in relation to actual profile of ground and tracks.
3. Applications can be found at <https://bnsf.railpermitting.com> and must be completed and submitted along with plans detailing location, both horizontal and vertical, of proposed utility with dimensions from track and/or right-of way boundaries.
4. The plans should contain the following data for carrier and casing pipe:
 - Contents to be carried
 - Inside diameter
 - Pipe material
 - Specifications and grade of pipe material
 - Wall thickness
 - Actual working pressure
 - Type of joints
 - Longitudinal joint factor
 - Coating
 - Method of Installation
 - Bore pit locations (measured perpendicularly from centerline of nearest track, must be 30' or more)
 - Vents-Number, Size, Location including Height above ground
 - Seals-Both ends, One end
 - Cover (top of tie to top of pipe casing)
 - Cover (other than under tracks)
 - Cover (at ditches)
 - Cathodic protection
 - Type, Size and Spacing of insulators or supports

5. Underground utility installations should be located on top of the back slope at the outer limits of railroad property as follows:

a. Electric power / Fiber Optic / Communication Lines

- i. A minimum depth of six (6) feet Below Natural Grade (BNG) for Electric and Fiber Optic Lines.
- ii. Whenever feasible, all cable should be laid within five (5) feet from property lines.
- iii. A 6-inch-wide warning tape will be installed, one (1) foot BNG directly over the underground fiber optic line when located on Railroad right-of-way outside the track ballast sections.

b. Pipelines

- i. Any pipeline installation paralleling BNSF property shall be within ten (10) feet of property line and a minimum of forty (40) feet from track.
- ii. If the pipeline is proposed to be located forty (40) feet or less from centerline of nearest track, the pipeline shall be encased in a steel pipe subject to approval from BNSF. No pipe may be placed closer than twenty-five (25) feet from centerline of any track. Pipe must be buried with a minimum cover of six (6) feet. If less than minimum depth is necessary because of existing utilities, water table, ordinance or similar reasons, the line shall be rerouted.
- iii. Locations where it will be difficult to attain minimum depth due to wet or rocky terrain shall be avoided. Any location change from plan must be approved by BNSF.
- iv. The use of plastic carrier pipe for sewer, water, natural gas, and other liquids is acceptable under specific circumstances. The use of plastic pipe is satisfactory if the pipe is designed to meet AREMA and all applicable federal and state codes, and if the carrier pipe is properly encased with a steel casing pipe for the entire length on BNSF right of way.
- v. Manholes shall be limited to those necessary for installation and maintenance of underground lines. Manholes vary as to size and shape depending on the type of utility they serve. To conserve space, their dimensions should be minimally acceptable by good engineering and safety standards. In general, the only equipment to be installed in manholes located on railroad property is that which is essential to the normal flow of the utility, such as circuit reclosers, cable splices, relays, valves, and regulators. Other equipment should be located outside the limits of the railroad property. Manholes shall not protrude above the surrounding ground nor be in the shoulder, shoulder slope, ditch, backslope,

or within twenty-five (25) feet of the centerline of track without approval of BNSF.

- vi. Pipelines must be marked every five hundred (500) feet and at every road crossing, streambed, other utility crossings, and at locations of major change in direction of the line.

c. Abandonment/Replacement/Removal of Facilities

- i. Upon abandonment, replacement or termination of license the utility needs to be removed from BNSF property except for the portion under the track embankment.
- ii. Portion of abandoned pipe under track embankment to remain in place shall be filled by pressure grouting. The grout material should be a sand cement slurry with a minimum of two (2) sacks of cement per cubic yard and a minimum amount of water to assure satisfactory placement. Open trenches shall be back-filled with BNSF approved materials and compacted to surrounding ground level.
- iii. An abandonment plan must be included in the general plans.

D. Attachment to Bridges and Other Structures

The Utility Owner will not be permitted to attach to BNSF bridges or route facilities through drainage structures or cattle passes. Utilities are not to be attached to other railroad structures without the written approval of BNSF Engineering. As a rule, overhead power, communication, and cable television line crossings at railroad bridges must be avoided. Pipelines laid longitudinally on railroad property shall be located as far as practical from any tracks or other important structures. If located within forty (40) feet of the centerline of any track, the carrier pipe shall be encased or be of special design as approved by BNSF Engineering.

E. Drains for Steep Slopes (Tight Lines)

Drainage onto BNSF property from adjacent land that is significantly higher than the track elevation should be directed through a pipe anchored into the steep slope. The pipe needs to be designed to withstand the weight of the water in the pipe. The drainage system will include a diffuser at the bottom to prevent erosion on BNSF property. See “Drains for Steep Slopes” diagram in the Appendix.



PART 3

UTILITIES PERPENDICULAR TO

RAILROAD PROPERTY

PART 3 - UTILITIES PERPENDICULAR TO RAILROAD PROPERTY

A. General Provisions

This section of the policy applies to all public and private utilities, including electric power, telephone, fiber optics, telegraph, cable television, water, gas, oil, petroleum products, steam, chemicals, sewage, drainage, irrigation, and similar lines that are located, adjusted, or relocated within the property under the jurisdiction of BNSF. Such utilities may involve underground, surface, or overhead facilities.

Installations crossing the property of the railroad, to the extent feasible and practical, are to be perpendicular to the railroad alignment and preferably at not less than forty-five (45) degrees to the centerline of the track. Utilities shall not be placed within culverts or under railroad bridges, buildings, or other important structures. New utilities should be placed at least twelve (12) feet from curb or edge of roadway pavement to avoid conflicts with existing or future active warning devices (crossing signals).

Utilities will be located to provide a safe environment and shall conform to the current “National Electrical Safety Code,” “American Waterworks Association Specifications,” “Federal Pipeline Safety Regulations,” and “The American Railway Engineering and Maintenance Association (AREMA) Recommendations.” Where laws or orders of public authority prescribe a higher degree of protection, then the higher degree of protection prescribed shall supersede the provisions of this manual.

Approval of plans and application forms is required for all installations of utilities prior to initiation of work on railroad property. A Professional Engineer’s seal is required for plans detailing:

- Pipelines installed within Shoring Zone A as shown in Figure 1, Pg 3-4, with an outside diameter greater than 8 inches; or
- Temporary shoring on the right-of-way; or
- Overhead pipeline bridge crossings; or
- Overhead electric transmission lines greater than 12.5 kV.

B. Overhead Installations

1. Must comply with all requirements of Part 1 – General Policy of this manual.
2. The design of all utility installations will be the responsibility of the Utility owner. Plans shall be drawn to scale showing the relationship of the proposed utility line to the railroad tracks, the angle of crossing, location of valves and vents, the railroad mile post and engineering station, railroad property lines and general layout of tracks and other railroad facilities. The plans should include a cross-section (or sections) from the field survey that will show utility placement in relation to actual profile of ground and tracks.
3. Applications can be found at <https://bnsf.railpermitting.com> and must be completed and submitted along with plans detailing location, both horizontal and vertical, of proposed utility with dimensions from track and/or right-of way boundaries.

4. Minimum four (4) feet clearance is required above existing signal and communication lines.
5. Poles must be located a minimum of fifty (50) feet out from the centerline of railroad main, branch and running tracks, CTC sidings, and heavy tonnage spurs. Pole location adjacent to industry tracks; must provide at least a 10-foot clearance from the centerline of track, when measured at right angles. If located adjacent to curved track, then said clearance must be increased at a rate of one and one-half (1-½) inches per degree of curved track.
6. Regardless of the voltage, un-guyed poles shall be located a minimum distance from the centerline of any track, equal to the height of the pole above the ground-line plus 10 feet. If guying is required, the guys shall be placed in such a manner as to keep the pole from leaning/falling in the direction of the tracks.
7. Poles (including steel poles) must be located a minimum distance from the railroad signal and communication line equal to the height of the pole above the ground-line or else be guyed at right angles to the lines. High voltage towers (34.5 kV and higher) must be located off railroad right of way.
8. Overhead crossings must not be installed within 500 feet of any railroad bridge, or 300 feet from the centerline of any culvert or track switch area.
9. Complete spanning of the property is encouraged with supportive structures and appurtenances located outside railroad property.
 - a. For electric supply lines, normally the crossing span shall not exceed 150 feet with adjacent span not exceeding 1-1/2 times the crossing span length.
 - b. For communication lines, the crossing span shall not exceed 100 feet in heavy loading districts, 125 feet in medium loading districts, and 150 feet in light loading districts; and the adjacent span shall not exceed 1-1/2 times the crossing span length. See Appendix for map of Loading Districts.
 - c. For heavier type construction, longer spans will be considered.
10. Joint-use construction is encouraged at locations where more than one utility or type of facility is involved. However, electricity and petroleum, natural gas or flammable materials shall not be combined. Pipe truss design and layout shall be sealed by a Professional Engineer and will need to be reviewed and approved by BNSF Engineering.
11. To ensure that overhead wire crossings are clear from contact with any equipment passing under such wires, lines shall be constructed with a minimum clearance above top of rail (ATR) as required by NESC + 3 feet or greater. Electric lines must have a florescent ball marker on lowest wire over centerline of track.
 - a. ≤ 750 volts (includes fiber optic) = 27'0" ATR (NESC + 3')
 - b. > 750 V and $< 50,000$ V = 29' 6" ATR (NESC + 3')
 - c. $\geq 50,000$ V = 27' (NESC) + 3 = 30' 0" ATR plus 0.4" per 1,000 V over 50kV
12. The utility owner will label the posts closest to the crossing with the owner's name and telephone number for emergency contact.

13. All overhead flammable and hazardous material lines will need BNSF Engineering approval but should be avoided if possible.
14. For proposed electrical lines crossing tracks, BNSF may request that an inductive coordination study be performed at the expense of the utility owner. Inductive interference from certain lines has the potential to disrupt the signal system in the track causing failures in the track signals and highway grade crossing warning devices. The General Director of Signals will determine the need for a study on a case-by-case basis.

C. Underground Installations

1. General

- a. Must comply with all requirements of Part 1 – General Policy of this manual.
- b. The design of all utility installations will be the responsibility of the Utility owner. Plans shall be drawn to scale showing the relationship of the proposed utility line to the railroad tracks, the angle of crossing, location of valves and vents, the railroad mile post and engineering station, railroad property lines and general layout of tracks and other railroad facilities. The plans should include a cross-section (or sections) from the field survey that will show utility placement in relation to actual profile of ground and tracks.
- c. Applications can be found at <https://bnsf.railpermitting.com> and must be completed and submitted along with plans, stamped by a Professional Engineer, detailing location, both horizontal and vertical, of proposed utility with dimensions from track and/or right-of way boundaries.
- d. The plans should contain the following data for carrier and casing pipe:
 - Contents to be carried
 - Inside diameter
 - Pipe material
 - Specifications and grade of pipe material
 - Wall thickness of pipe
 - Actual working pressure
 - Type of joints
 - Longitudinal joint factor
 - Coating
 - Method of Installation
 - Bore pit locations (measured perpendicularly from centerline of nearest track, must be 30' or more)
 - Vents-Number, Size, Location and Height above ground
 - Seals-Both ends, One end
 - Cover (top of tie to top of pipe casing)
 - Cover (other than under tracks)
 - Cover (at ditches)
 - Cathodic protection
 - Type, Size and Spacing of insulators or supports

- e. All underground utility crossings of railroad trackage shall be designed to carry Cooper's E-80 Railroad live loading with diesel impact (*Design Loads* Section Found in AREMA Manual for Railway Engineering, Chapter 8 section 2.2.3) and on page 3-10 of this manual for reference. This 80,000-lb. axle load may be distributed laterally a distance of three (3) feet, plus a distance equal to the depth from structure grade line to base of rail, on each side of centerline of single tracks, or centerline of outer track where multiple tracks are to be crossed. In no case shall railroad loading design extend less than ten (10) feet laterally from centerline of track. Longitudinally, the load may be distributed between the five-foot axle spacing of the Cooper configuration. Railroad loading criteria will also apply where future tracks on BNSF are contemplated, to the extent this information is available.
- f. All utilities crossing under ditches and railroad trackage using jacking and dry boring installation should have a minimum depth of cover of six (6) feet below the flowline of the ditch or ground surface and eight (8) feet – three (3) inches from base of rail. In fill sections, the natural ground line at the toe of slope will be considered as ditch grade.
- i. Boring pits shall be located outside railroad property, when possible, at a minimum of thirty (30) feet from the centerline of track and kept to the minimum size necessary. Do not locate the bore pits in the slope of a cut or fill section of the roadbed. Keep the bore pit size to a minimum. Use shoring, temporary or permanent, conforming to the most restrictive of state, OSHA, or AREMA recommended practices in all excavations, where required. A list of items to be included in the Shoring Plan is shown on the Review Comments Sheet in the Appendix.
 - 1) Shoring Zones (see Figure 1 below):
 - a. All dimensions are measured perpendicular to the centerline of track.
 - b. For ALL excavations within Zone A, shoring plans and calculations, sealed by a Professional Engineer, shall be submitted with the application.
 - c. All shoring within the limits of Zone A must be placed prior to the start of excavation.

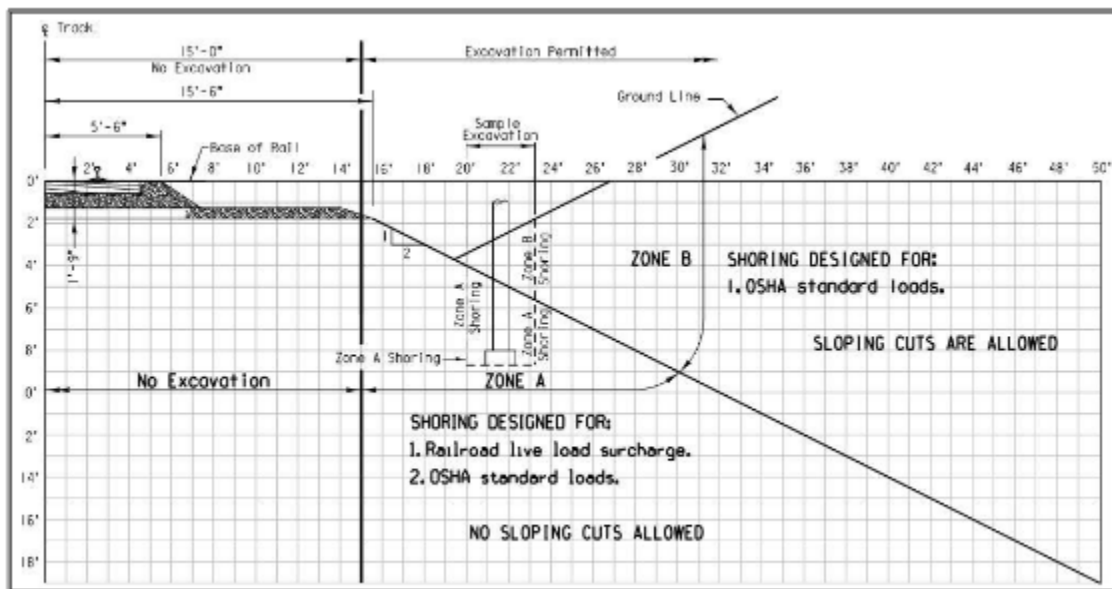
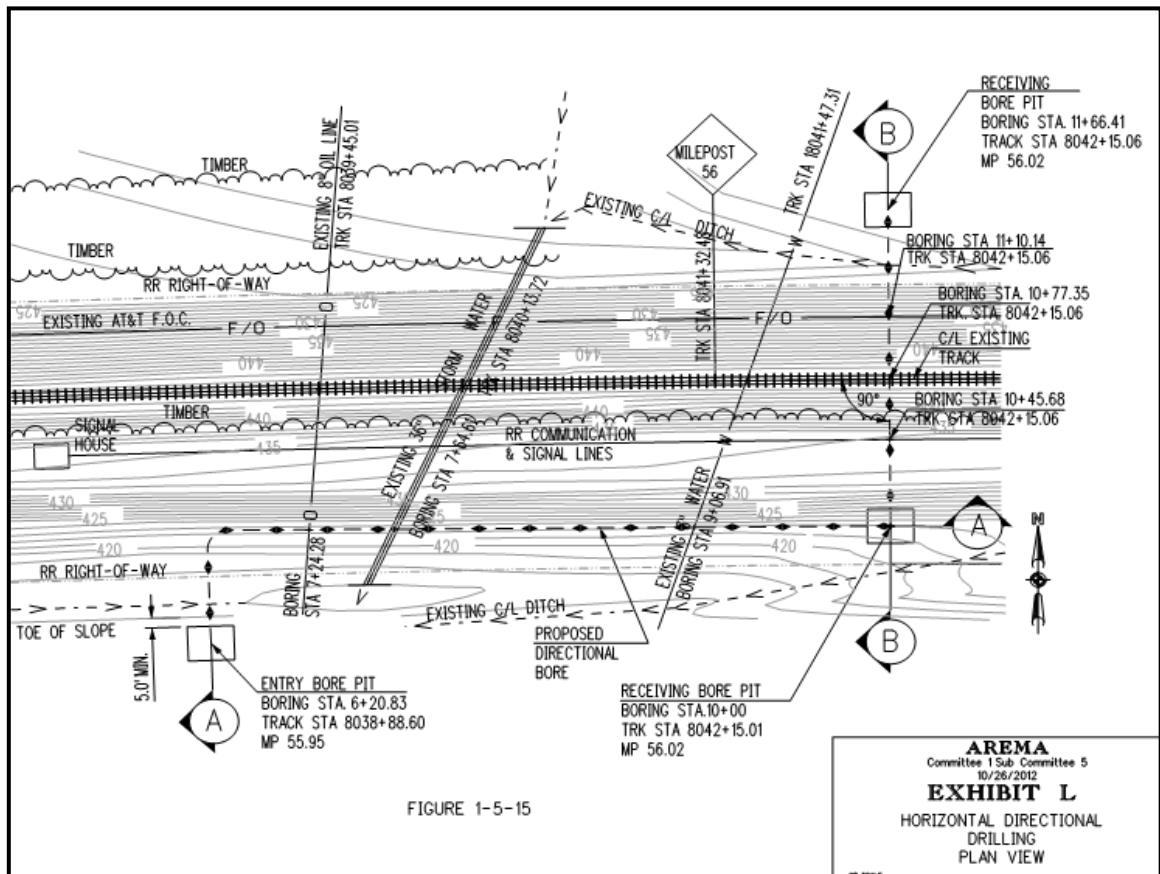

FIGURE 1

- ii. All excavations will be attended or protected. Fence, fill or guard each site prior to leaving. Monitor shored excavations continuously during work for signs of instability and failure.
- iii. Under-track bores using jack-and-bore method shall be located greater than forty-five (45) feet from the nearest bridge, culvert, track switch area, building or other major structure, regardless of commodity.
- iv. For any installation other than jack and bore under main and siding tracks greater than twenty-six (26) inches in diameter and less than twelve (12) feet below base of rail, a geotechnical study will need to be performed to determine the presence of granular material and/or high-water table elevation, at the sole expense of the Permittee. The study will include recommendations and a plan for a procedure to prevent failure and a potential collapse of the bore. Generally, core samples are to be taken near the ends of tie at the proposed location, at least as deep as the bottom of the proposed horizontal bore. Test results must be reviewed and approved by BNSF, or its agent, prior to boring activities commencing. BNSF reserves the rights, based on test results, to require the Permittee to select an alternate location, or to require additional engineering specifications be implemented, at the sole expense of the Permittee, to utilize existing location.
- v. BNSF Engineering will not need to review projects involving underground crossings of uncased gravity-flow sewer pipelines provided the material is one of the following:
 - 1) Class V reinforced concrete pipe (RCP).
 - 2) Steel pipe with proper wall thickness as prescribed in this policy.
 - 3) HOBAS pipe.

- g. All utilities crossing under ditches and railroad trackage using horizontal directional drilling (HDD) installation should have a minimum depth of cover of six (6) feet below the flowline of the ditch or ground surface and twelve (12) feet from base of rail. In fill sections, the natural ground line at the toe of slope will be considered as ditch grade. Detailed drawings should be included with the application.

Example detailed drawings to be submitted:



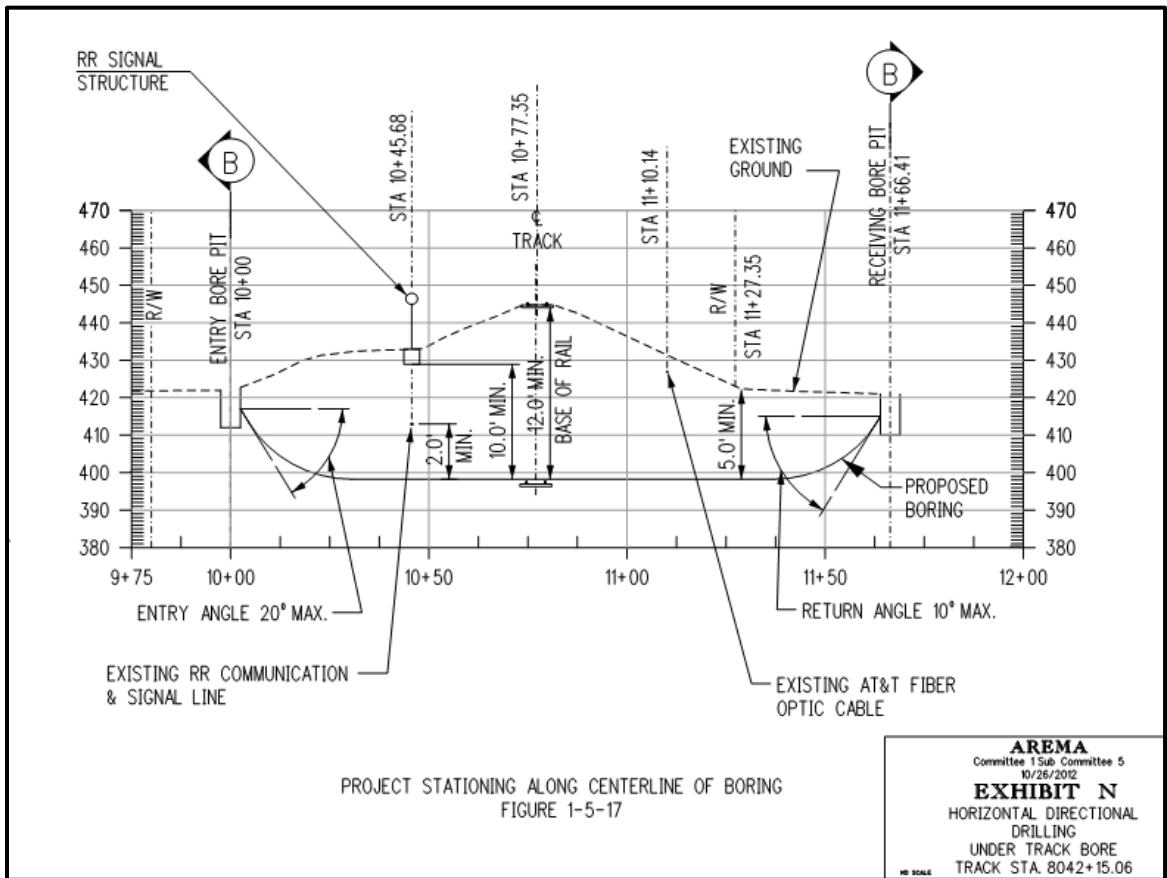

- h. Underground installations may be made by open trenching from the property line to the toe of the fill slope in fill sections and to the toe of the shoulder slope in cut sections but to no closer than thirty (30) feet of the centerline of track.
- i. Underground installations crossing or paralleling BNSF will need to be a minimum of six (6) feet below natural ground / ditches regardless of installation method.
- j. The use of plastic carrier pipe for sewer, water, natural gas, and other liquids is acceptable under specific circumstances. The use of plastic pipe is satisfactory if the pipe is designed to meet all applicable federal and state codes, and if the carrier pipe is properly encased within a steel casing pipe per AREMA standards. This casing must extend the full width of the right of way.
- k. If the minimum depth is not attainable because of existing utilities, water table, ordinances, or similar reasons, the line shall be rerouted.
- l. Locations that are considered unsuitable or undesirable are to be avoided. These include deep cuts and in wet or rocky terrain or where it will be difficult to obtain minimum depth.
- m. Manholes should be located outside railroad property, when possible. No manhole may be in the shoulder, shoulder slope, ditch or backslope, or within twenty-five (25) feet of the centerline of any track and shall not protrude above the surrounding ground without approval of BNSF.

- n. Utilities, except temporary water lines, will not be attached to or routed through drainage structures or cattle passes. Utilities are not to be attached to other railroad structures without written approval of the BNSF Structures Department.
- o. Crossings shall not be installed under or within forty-five (45) feet of any Railroad bridge, track switch area or the centerline of any culvert unless installed at a depth equal to or greater than twelve (12) below base of rail.
- p. A BNSF signal representative must be present during installation if railroad signals are in the vicinity of wireline crossings unless signal representative authorizes otherwise.
- q. Markers that identify the Utility Owner shall be placed at both property lines for utilities crossing the railroad property. Parallel lines must be marked every five hundred (500) feet and at every road crossing, streambed, other utility crossings, and at locations of major change in direction of the line. The markers should identify the owner, type of cable and emergency telephone number. A six (6) inch wide warning tape will be installed one (1) foot BNG directly over the underground power line when located on Railroad right-of-way and outside the track ballast sections.
- r. Above-ground utility appurtenances installed as a part of an underground installation shall be located at or near the railroad property line and shall not be any closer than twenty-five (25) feet to the centerline of track.

2. Pipeline Requirements

- a. Pipeline designs are to specify the type and class of material, maximum working pressures, test, and design pressure. All pipes are to be constructed per most recently published or regulated standard of the USDOT Hazardous Material Regulation Board.
- b. Pipelines carrying oil, liquefied petroleum gas, natural or manufactured gas and other flammable products shall conform to the requirements of the current AREMA, ANSI/ASME B 31.4 Code for pressure piping - Liquid Petroleum Transportation Piping Systems; ANSI B 31.8 Code for pressure piping - Gas Transmission and Distribution Piping Systems; other applicable ANSI codes and 49 C.F.R. Part 192 – Transportation of Natural and Other Gas by Pipeline: Minimum Federal Safety Standards or Part 195 - Transportation of Hazardous Liquids by Pipeline, except that the maximum allowable stress of design of steel pipe shall not exceed the specified minimum yield strength (multiplied by longitudinal joint factor) of the pipe as defined in the ANSI codes.
- c. New and relocated sewer lines shall be constructed with satisfactory joints, materials and designs which will provide protection and resistance to damage from sulfide gases and other corrosive elements to which they may be exposed. Where non-metallic pipe is permitted and installed, a durable metal wire shall be concurrently installed; or other means shall be provided for detection purposes.
- d. Pipelines under railroad tracks and across railroad property shall be encased in a larger pipe or conduit called “casings.” Generally, casings shall extend from right-of-way line to right-of-way line, unless otherwise approved.

- e. Pipelines and casing pipes shall be suitably insulated from underground conduits carrying electric wires on railroad property.
- f. Reinforced concrete pipe, with storm water and sewer being the exception, will need to be encased for a distance as wide as the embankment at the utility crossing. This is to protect against track failure due to joint separation.

3. Encasement of Utilities

- a. Casings are oversized load-bearing conduits or ducts through which a utility is inserted:
 - i. To protect the railroad from damages and to provide for repair, removal, and replacement of the utility without interference to railway traffic.
 - ii. To protect the carrier pipe from external loads or shock, either during or after construction.
 - iii. To convey leaking fluids or gases away from the area directly beneath the railroad trackage to a point of venting at the railroad property line.
 - iv. Casing may be omitted for **gaseous products only** if the carrier pipe is steel, the wall thickness conforms to E-80 loading shown in the table on page 3-10, the pipe is cathodically protected with an active induced current, or a passive system that could include sacrificial anodes and/or a protective coating rated for “cathodic protection;” and is placed twelve (12) feet minimum below the base of rail per AREMA standards.
 - v. Underground electric and fiber installations must be encased completely across the Railroad right-of-way with a rigid conduit. The conduit can be steel, HDPE SCH 80, HDPE SDR-11, or HDPE SDR-9 (with no casing pipe for a single conduit). Any installations crossing BNSF with multiple duct installations must be in a single casing unless they are placed 5’ or more apart. A metallic ribbon or wire must be included in the pipe to allow for radio locating later.
 - vi. Casing may be omitted for other products under all three of the following circumstances:
 - (a) When carrier pipe is steel, and the wall thickness conforms to E-80 loading for casing pipe shown in the table on page 3-10 and as included in AREMA manual Chapter 1, Part 5 for Utility Crossings. The length of the pipe shall extend from railroad right-of-way line to right-of-way line, and
 - (b) When steel carrier pipe is cathodically protected with an active induced current, or a passive system that could include sacrificial anodes and/or a protective coating rated for “cathodic protection;” and
 - (c) When the depth from base of rail to top of pipe is equal to or greater than thirty (30) feet and minimum depth of cover is six (6) feet below the flowline of the ditch or ground surface.

- b. In circumstances where it is not feasible to install encasement from right-of-way line to right-of-way line, casing pipe under railroad tracks and across railroad property shall extend to the greater of the following distances, measured at right angles to the centerline of track:
 - i. Two (2) feet beyond toe of slope.
 - ii. Three (3) feet beyond ditch line.
 - iii. Twenty-five (25) feet from centerline of outside track when casing is sealed at both ends.
 - iv. Forty-five (45) feet from centerline of outside track when casing is open at both ends.
 - v. Extend across the entire length of Shoring Zone A as shown in Figure 1, Pg 3-4.
 - vi. If additional track is planned for future construction, casing must extend far enough to meet above distances given the additional track requirement.
- c. Pipelines and casing pipe shall be suitably insulated from underground conduits carrying electric wires on railroad property.
- d. Casing pipe and joints shall be made of metal, and of leakproof construction. Casings shall be capable of withstanding the railroad loadings and other loads superimposed upon them.

- e. Wall thickness designations for steel carrier and casing pipe for E-80 loading (including impact) are:

Nominal Diameter (inches)	Minimum Wall Thickness (inches)
12-3/4 and under	0.188
14	0.188
16	0.219
18	0.250
20 and 22	0.281
24	0.312
26	0.344
28	0.375
30	0.406
32	0.438
34 and 36	0.469
38	0.500
40	0.531
42	0.562
44 and 46	0.594
48	0.625
50	0.656
52	0.688
54	0.719
56 and 58	0.750
60	0.781
62	0.812
64	0.844
66 and 68	0.875
70	0.906
72	0.938

- i. Steel pipe shall be in conformance with ASTM A1097 and of leakproof construction, such as butt welded or interlocking joints which are capable of withstanding railroad loading. Pipe shall have a specified minimum yield strength, SMYS, of at least 35,000 psi (pounds per square inch / 241,317kPa).
- ii. All metallic casing pipes are to be designed for effective corrosion control, long service life and relatively free from routine servicing and maintenance. Corrosion control measures for metallic casing pipe must include cathodic protection which can be an active induced current, or a passive system that could be sacrificial anodes and/or protective coating rated for cathodic protection such as fusion bonded epoxy with an abrasion resistant overcoating.
- iii. Cast iron may be used for casing. It shall conform to ANSI A21. The pipe shall be connected by mechanical-type joints. Plain-end pipe shall be connected by compression-type couplings. The strength of the cast iron pipe to sustain external

loads shall be computed in accordance with the most current ANSI A21.1 “Manual for the Computation of Strength and Thickness of Cast Iron Pipe.”

- f. The inside diameter of the casing pipe shall be such that the carrier pipe can be removed without disturbing the casing. All joints or couplings, supports, insulators or centering devices for the carrier pipe shall be considered in the selection of the casing diameter.
- g. For flexible casing pipe, a maximum vertical deflection clearance of the casing pipe shall be three percent (3%) of its diameter plus one-half (1/2) inch so that no loads from the roadbed, track, railroad traffic or casing pipe are transmitted to the carrier pipe. When insulators are used on the carrier pipe, the relationship of the casing size to the size of the carrier pipe is:

<u>Diameter of Carrier Pipe</u>	<u>Inside Diameter of Casing Pipe Equals Outside Diameter of Carrier Pipe Plus</u>
0" – 7.9"	2"
8" - 16"	3-1/4"
Over 16"	4-1/2"

4. Casing and Pipeline Installation

- a. Casing and pipeline installations should be accomplished by Horizontal Directional Drilling (HDD), dry jack-and-bore, tunneling or other approved methods. Tunneling construction under tracks will be permitted only under direct supervision of a BNSF Engineer. Tunneling procedures and equipment, as well as structural design, must have BNSF Engineering approval prior to starting any work on BNSF property. Generally, tunneling shall not be considered where less than six (6) feet of cover exists, or where excessively sandy, loose, or rocky soils are anticipated.

All utilities crossing under ditches and railroad trackage using jacking and dry boring installation should have a minimum depth of cover of six (6) feet below the flowline of the ditch or ground surface and eight (8) feet – three (3) inches from base of rail. In fill sections, the natural ground line at the toe of slope will be considered as ditch grade.

Jacking/boring pits shall be located outside railroad property, when possible, at a minimum of thirty (30) feet from the centerline of track and kept to the minimum size necessary. Do not locate the bore pits in the slope of a cut or fill section of the roadbed. Keep the bore pit size to a minimum. Use shoring, temporary or permanent, conforming to the most restrictive of state, OSHA, or AREMA recommended practices in all excavations, where required. Submit shoring plans sealed by a Professional Engineer with application for approval prior to construction.

Under-track bores using jack-and-bore method shall be located greater than forty-five (45) feet from the nearest bridge, culvert, track switch area, building or other major structure, regardless of commodity.

All encased utility pipeline crossings under ditches and railroad trackage using horizontal directional drilling (HDD) installation should have a minimum depth of

cover of six (6) feet below the flowline of the ditch or ground surface and twelve (12) feet from base of rail. In fill sections, the natural ground line at the toe of slope will be considered as ditch grade. Detailed drawings should be included with the application.

Rail elevations over the work must be monitored at intervals prescribed by BNSF to detect any track movement. Movements of over one-quarter (1/4) inch vertically shall be immediately reported to the BNSF Roadmaster. Due to the danger to rail traffic that is caused by only small amounts of track movement, BNSF forces may have to be called to surface the track several times. The cost of any work required by BNSF in the repair of track caused by utility installation will be assessed against the Utility Owner.

The following requirements shall apply to these construction methods:

- i. The use of water under pressure, jetting or puddling will not be permitted to facilitate boring, pushing or jacking operations. Some boring may require water to lubricate cutter and pipe, and under such conditions, is considered dry boring.
- ii. Where unstable soil conditions exist, boring or tunneling operations shall be conducted in such a manner as not to be detrimental to the railroad being crossed.
- iii. If excessive voids or too large of a bored hole is produced during casing or pipeline installations, or if it is necessary to abandon a bored or tunneled hole, prompt remedial action should be taken by the Utility Owner.
- iv. All voids or abandoned holes caused by boring, or jacking are to be filled by pressure grouting. The grout material should be a sand cement slurry with a minimum of two (2) sacks of cement per cubic yard and a minimum of water to assure satisfactory placement.
- v. For bored or tunneled installations less than seventeen and one-half (17-1/2) feet deep, less than 300 feet long and pipe diameters less than or equal to 20 inches, the hole diameter shall not exceed the outside diameter of the utility pipe, cable, or casing (including coating) by more than one and one-half (1-1/2) inches for pipes with an inside diameter of twelve (12) inches or less, or two (2) inches on pipes with an inside diameter greater than twelve (12) inches.
- vi. For bored or tunneled installations seventeen and one-half (17-1/2) feet deep or deeper, 300 feet long or longer, or greater than 20 inches in pipe diameter, the hole diameter shall not exceed one and one-half (1-1/2) times the diameter of the pipe.

This is further clarified as follows:

Hole Diameter	Depth	Length	Pipe Outside Diameter
Pipe OD + 1-1/2"	< 17.5'	<300'	<=12"
Pipe OD + 2"	< 17.5'	<300'	12" <= 20"
Pipe OD x 1.5	> 17.5'	>= 300'	> 20"

- b. Vents. In casing pipe installations, vents are appurtenances by which fluids or gases between carrier and casing may be inspected, sampled, exhausted, or evacuated.
 - i. Vent standpipes shall be located and constructed so as not to interfere with maintenance of the railroad or to be concealed by vegetation. Where possible, they shall be marked and located at the property line. The markers shall give the name, address of the owner, and a 24-hour phone number to contact in case of emergency.
 - ii. Casing pipe, when sealed, shall be properly vented. Vent pipes shall be of sufficient diameter, but in no case less than two (2) inches in diameter and shall be attached near each end of casing projecting through ground surface at property lines.

Seals and vents shall be required for all encased pipelines carrying flammable substances under pressure to ensure the flammable substances are evacuated away from the track and subgrade in the event of a pipe failure. Vents shall be located at both ends of the casings.

Venting is not required for encased water lines; however, sealing will be required if the ends of the casing are not above the high-water table.

Where casing pipe is used on sewer lines, venting, and sealing of casing will be required on pressurized lines.

- iv. Vent pipes shall extend not less than four (4) feet above ground surface. Top of vent pipes shall be fitted with a down-turned elbow, properly screened, or a relief valve.
- v. Vent pipes on casings shall be at least four (4) feet (vertically) from aerial electric wires. Casings shall be suitably insulated from underground conduits carrying electric wires on Railroad right-of-way.

c. Shut-Off Valves

- i. The Utility Owner shall install accessible emergency shut-off valves on each side of the railroad. Locating a shut-off valve on railroad property should be avoided. If approval is acquired, a guardrail must protect the shut-off valve.
- ii. When a guardrail is required, its height shall be four (4) feet above the ground line. All four corner posts shall be driven to a minimum depth of four (4) feet below ground line. There shall be a minimum clearance of two (2) feet from the valve to the guardrail. The steel pipes for the four corner posts and guardrail shall have a minimum diameter of four (4) inches. All joints will be welded with a one-quarter (1/4) inch fillet weld all around.
- iii. Where pipelines are provided with automatic control stations, no additional valves will be required.

5. Abandonment/Replacement/Removal of Facilities

- a. Upon abandonment, replacement or termination of license the utility needs to be removed from BNSF property except for the portion under the track embankment (as shown in Appendix “Retirement/Removal of Pipelines on BNSF Property”).
- b. Portion of abandoned pipe under track embankment to remain in place shall be filled by pressure grouting. The grout material should be a sand cement slurry with a minimum of two (2) sacks of cement per cubic yard and a minimum amount of water to assure satisfactory placement. Open trenches shall be back-filled and compacted to surrounding ground level.
- c. Abandoned or replaced poles shall be removed from BNSF property or cut off to a depth at least six (6) feet below ground; and the hole filled with BNSF approved material and compacted to surrounding ground level.
- d. All metal such as rebar, cable, anchor systems, and strain relief must be removed and disposed of in accordance with local, state and federal regulations.
- e. An abandonment plan must be included in the general plans.



APPENDIX

OVERHEAD INSTALLATIONS

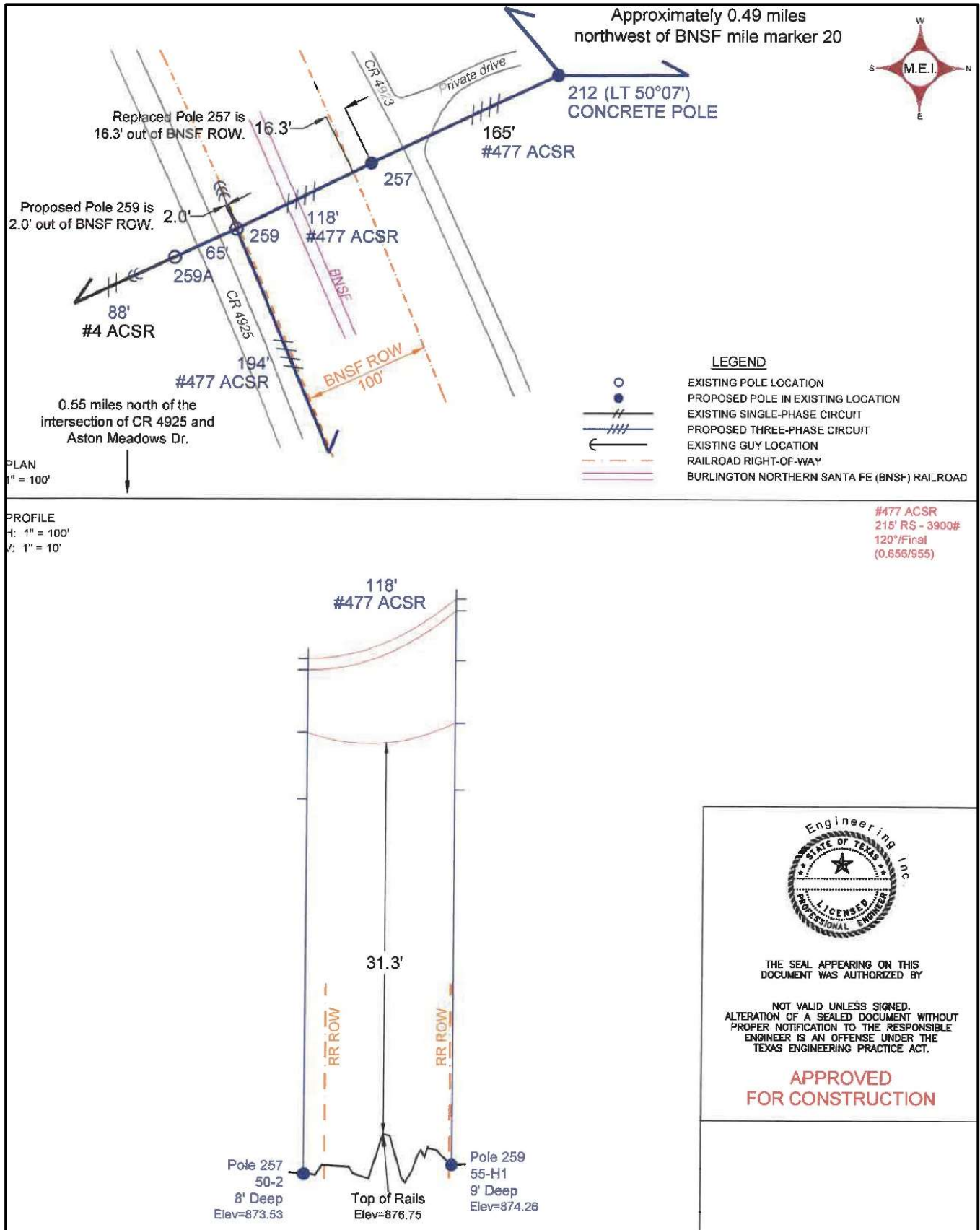

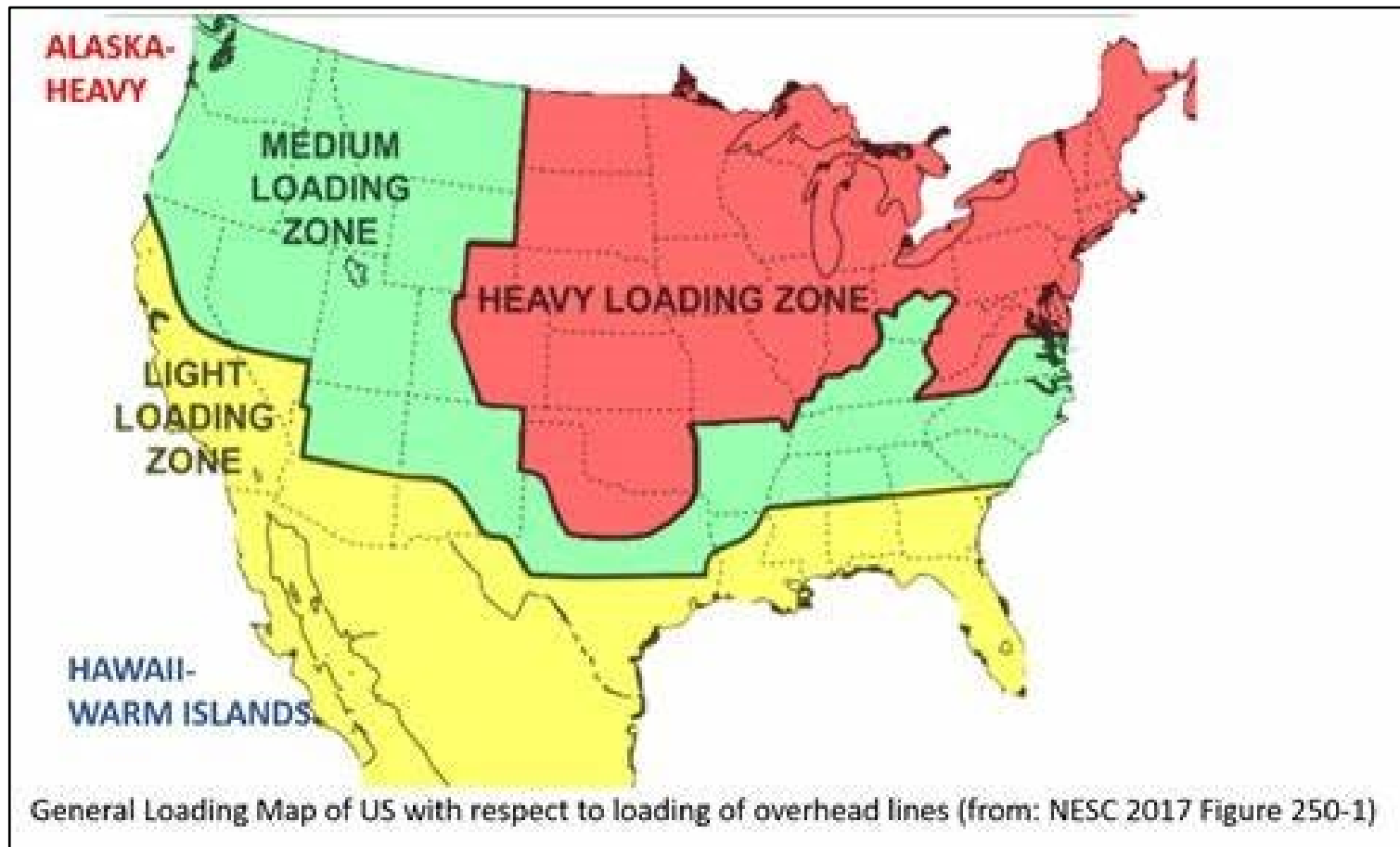

Loading districts (or zones) to determine minimum span length for overhead wirelines crossing over tracks. If location is in question with reference to load rating, use the higher rating.

UNDERGROUND INSTALLATIONS

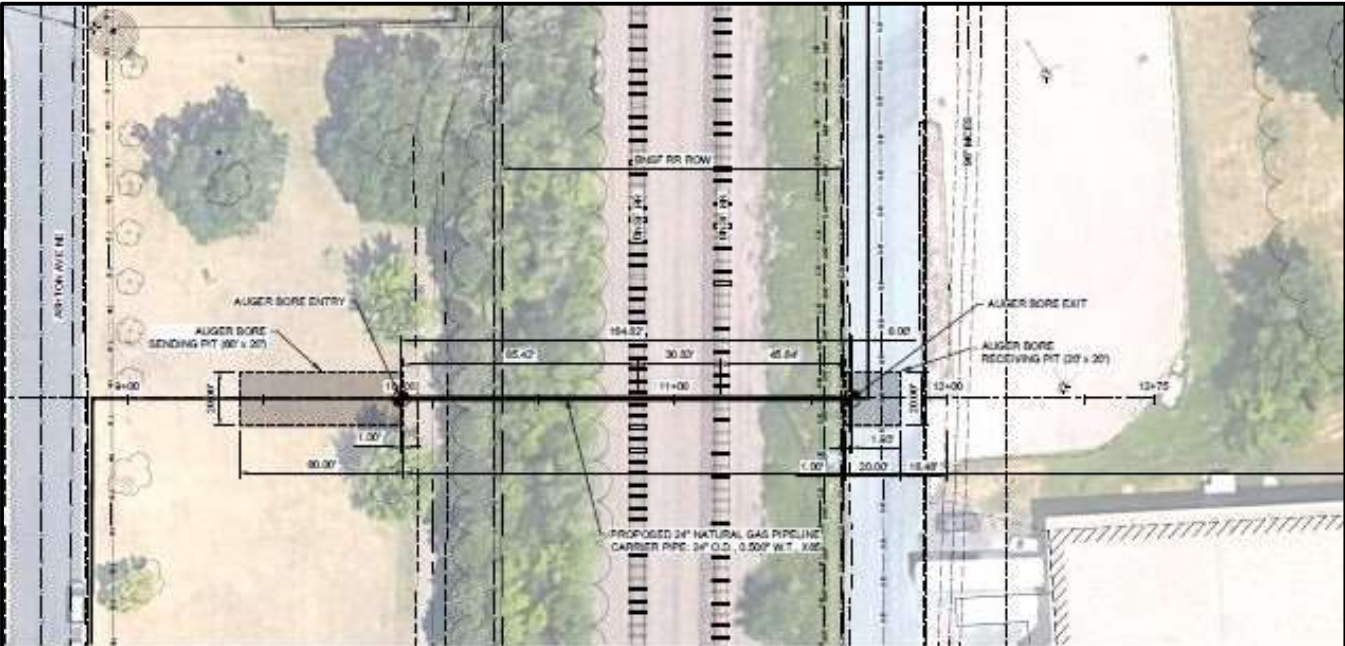

PLAN

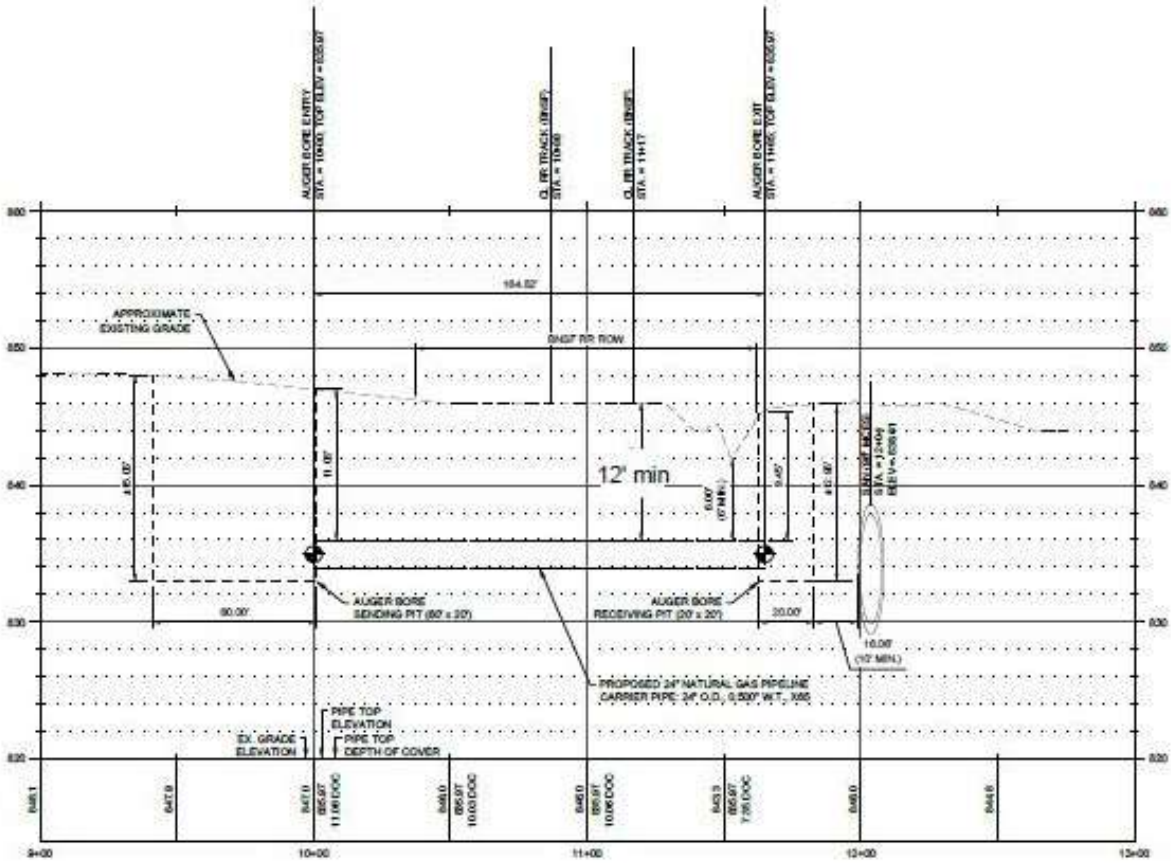

PROFILE



**UNDERGROUND INSTALLATION
JACK AND BORE EXAMPLE**

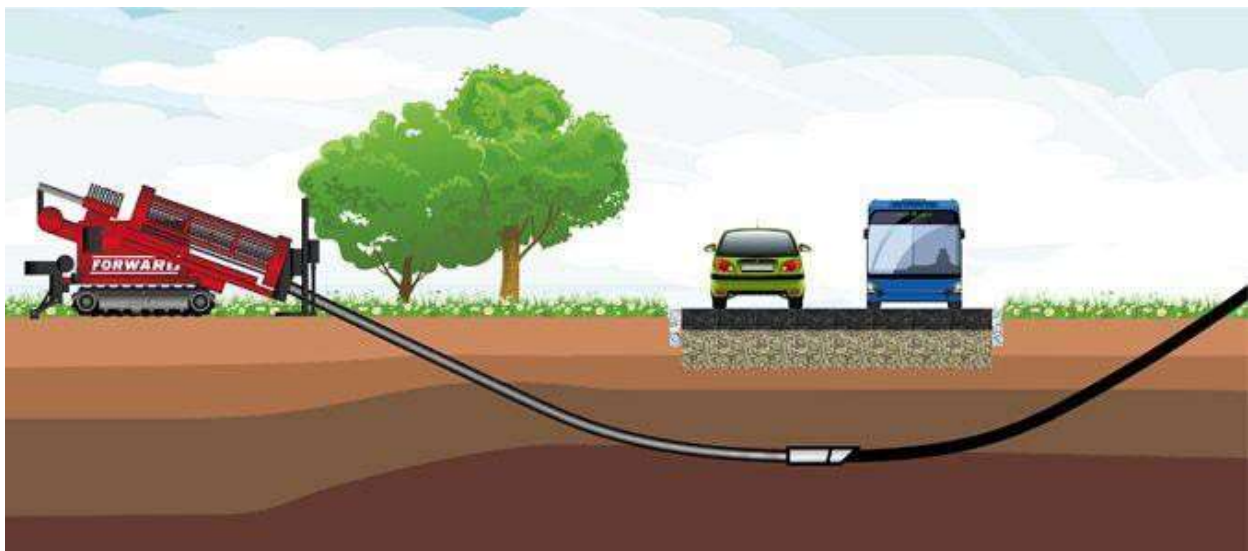

**UNDERGROUND INSTALLATION
HORIZONTAL DIRECTIONAL DRILLING (HDD) EXAMPLE**

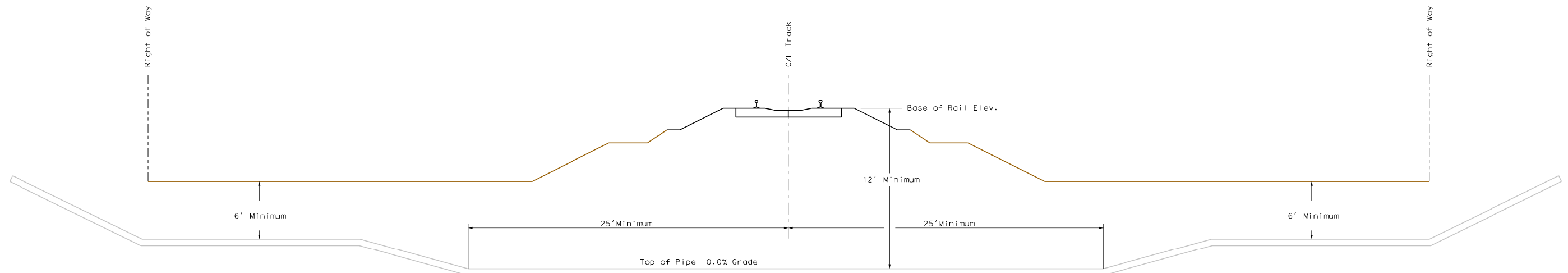

Cutting head must travel at 0.0% grade (or downward) beginning 25' (minimum) from centerline of track until it reaches a point 25' (minimum) from the centerline of track. Minimum pressure must be applied to pumping the slurry to the cutting head during drilling. This will deter the bentonite slurry used for lubrication from seeping up and fouling the track roadbed.

The plans submitted with the application must show the planned travel path of the cutting head.

A construction observer must be present during installation and will monitor the ballast and roadbed.

APPROVALS	TITLE	DATE	REVISIONS				DATE: 06/20/08	<i>HORIZONTAL DIRECTIONAL DRILLING STANDARDS NOT TO SCALE</i>
			NO.	DESCRIPTION	DATE	BY		
			1	Added "minimum" to distance from track	9/19/08	JRG		
			2	Revised minimum depth requirements	9/8/20	BAL		
			DESIGNED:	ENGINEERING SERVICES www.bnsf.com/tools/fieldengineering/index	FILE NO.		LS/mp:	
			DRAWN:		RFA / AFE NO.		DIVISION:	
			CHECKED:		STATUS		SUBD:	
							\utilaccom\hdd.dgn	



No Comment / All Items CLOSED*

Submittal Essentials in RED **

I/C & Project Engineer Review Items; [KC Structures Review Items](#)

BNSF Engineering Services-Structures Review Comments

Temporary Shoring Review Comments Sheet

Check for compliance with current AREMA and [BNSF/UP Temporary Shoring Guidelines](#)

Project Name:		BNSF Point of Contact:	
Submittal Name:		Project CM Contact:	
Plan File Name:		Asset MP Name:	
Plan File Date:		Plan %:	

Professional Engineer Seal & Signature (Plans and Calculations)

No Exceptions Taken Comments Below N/A

Show offset face of shoring to CL Tracks at all Changes in Horizontal Alignment

No Exceptions Taken Comments Below N/A

Show BNSF ROW Limits, all tracks labeled w/ track spacing

No Exceptions Taken Comments Below N/A

Show Grading at Wall Ends, No More than 2:1 Slopes

No Exceptions Taken Comments Below N/A

All OH and underground utilities located (include fiber, BNSF signal, telecom)

No Exceptions Taken Comments Below N/A

Provide Calculations (Include sample hand calcs w/ assumptions listed)

No Exceptions Taken Comments Below N/A

Meets deflection criteria

No Exceptions Taken Comments Below N/A

No Tiebacks under track

No Exceptions Taken Comments Below N/A

Substructure Removal Limits (Lesser of 3' below GL or TOT)

No Exceptions Taken Comments Below N/A

Provide geotechnical report (in-situ soil classification, P_a, P_p, etc.)

No Exceptions Taken Comments Below N/A

Drainage Along the Wall, Through the Wall

No Exceptions Taken Comments Below N/A

Handrail Heights and Lengths Detailed

No Exceptions Taken Comments Below N/A

Check FS of overturning for sheeting

No Exceptions Taken Comments Below N/A

Gravity shoring systems analyzed for OT, SL and global stability

No Exceptions Taken Comments Below N/A

Need Shoring Loading Zones shown

Within Zone A Zone B Only Zone C Only

TOT, Top of Wall Elevations Shown on General Plan

No Exceptions Taken Comments Below N/A

Horizontal Clearance to CL Tracks at right angle to Nearest Obstruction

No Exceptions Taken Comments Below N/A

Show Total Depth of Shoring System w/ controlling dimensions

No Exceptions Taken Comments Below N/A

Call Before You Dig" Numbers - BNSF Fiber - 1-800-533-2891

BNSF Signal - 1-800-832-5452

No Exceptions Taken Comments Below N/A

Temp Shoring Specific: E80 Loading Properly Applied

No Exceptions Taken Comments Below N/A

Monitoring Plan: Triggering & max values, survey locations and frequency

No Exceptions Taken Comments Below N/A

Item No.	Sheet No.	Reviewer Comment Date:	Initial	Designer's Response Date:	Reviewer's Comment Date:	Initial	Designer's Response Date:	Reviewer's Comment Date:	Initial	Designer's Response Date:	Reviewer's Comment Date:	Initial	Status (Open or Closed)
1.													
2.													
3.													
4.													
5.													
6.													

*BNSF has reviewed these submittals and no exceptions are taken with regard to BNSF's ability to use or accommodate the project as intended. BNSF has not reviewed the design details or calculations for structural integrity or engineering accuracy. BNSF accepts no responsibility for errors or omissions in the design or execution of the project.

** Check Submittal Essentials prior to transmittal to Structures Review. If not included, Project Engineer to reject and request resubmittal.

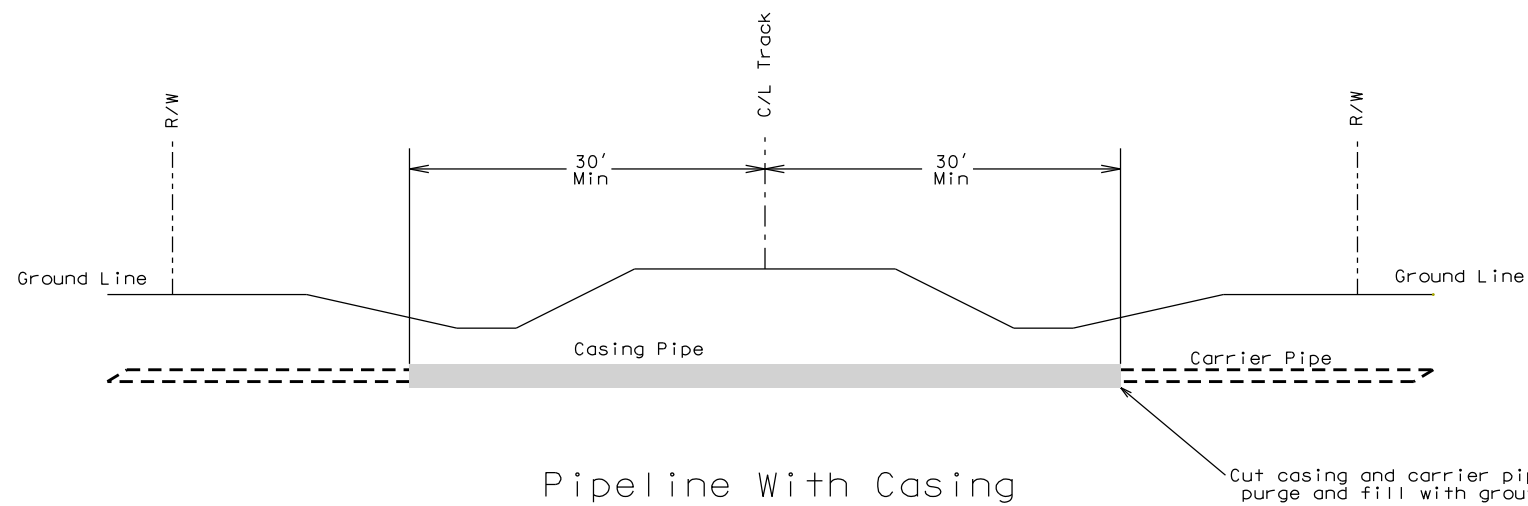

Pipeline With Casing

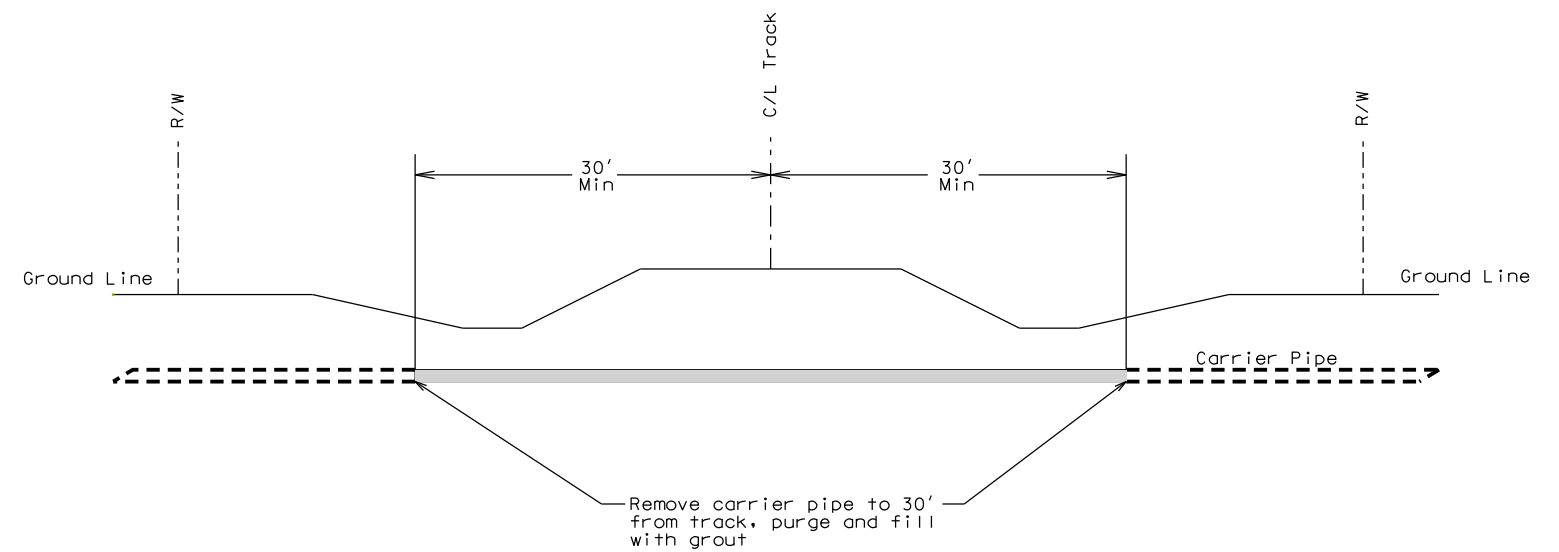

Pipeline Without Casing

Upon termination all pipelines and casings will be removed entirely from BNSF property up to the toe of track embankment, but no closer than 30' from centerline of track.

APPROVALS - (NAME - TITLE)	DATE	APPROVALS - (NAME - TITLE)	DATE



RETIREMENT/REMOVAL OF PIPELINES ON BNSF PROPERTY

REVISIONS			
NO.	DESCRIPTION	DATE	BY

DRAINS FOR STEEP SLOPES

Installation of the pipeline will be difficult due to the slope in which the pipe will be laid. Any damage to the slope due to construction must be repaired to its original condition. A large load on the concrete anchor which supports the pipe at the top of the slope will result due to this installation. This anchor should be moved as far away from the face of the slope as possible to maximize its support capability. The pipeline should be designed to withstand the weight of the water within the pipe.

See details below commonly used to support and hold the pipe in place, which should be used for this installation. If the pipeline fails, it will be the owners responsibility to reinstall the pipeline. If damage occurs to railway property due to the failure of the pipeline, the property owner will be responsible for damages. The property owner must not deposit grass clippings, yard waste, trees or other debris on the slope at any time.

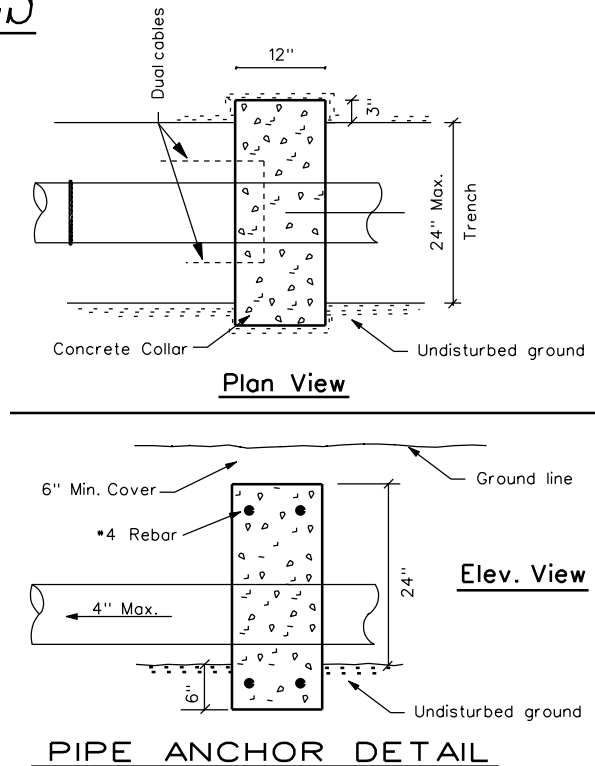

#4 U-shaped rebar bent to pipe shape and placed not less than 30" into ground at 25' intervals.

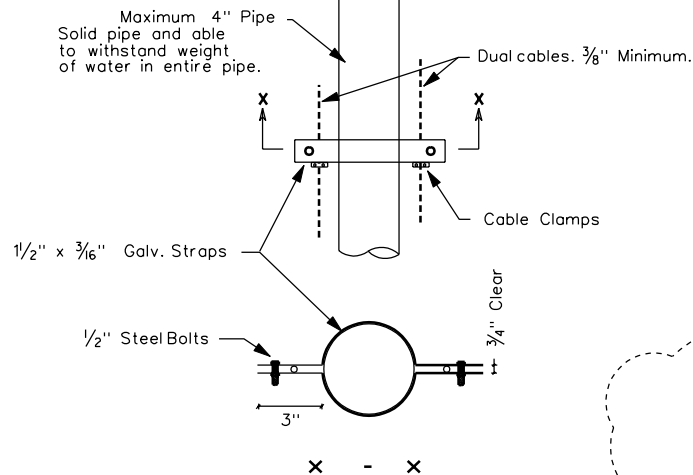

CLAMP DETAIL

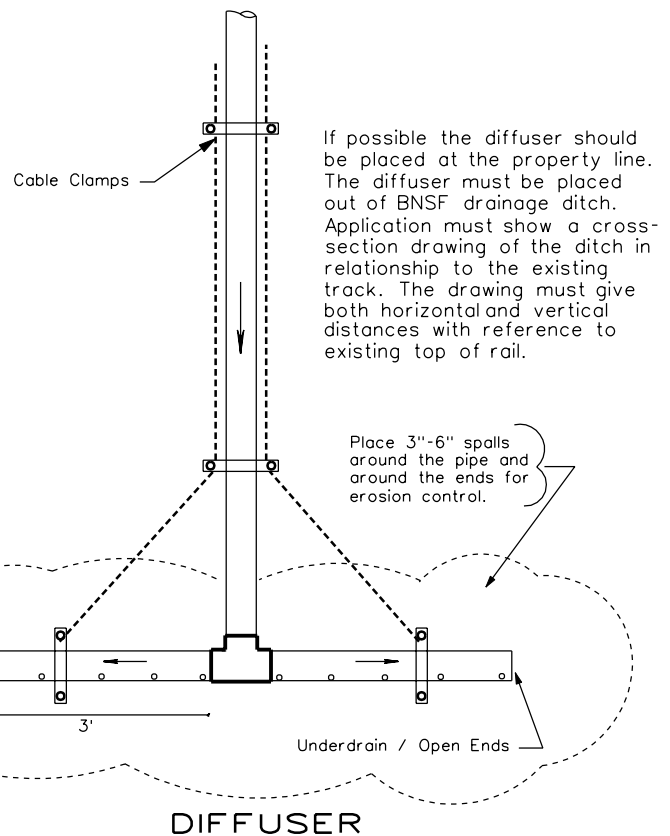

If possible the diffuser should be placed at the property line. The diffuser must be placed out of BNSF drainage ditch. Application must show a cross-section drawing of the ditch in relationship to the existing track. The drawing must give both horizontal and vertical distances with reference to existing top of rail.

Place 3"-6" spalls around the pipe and around the ends for erosion control.

DIFFUSER

NOT TO SCALE

DEFINITION OF TERMS

The terminology used in this Policy strives for conventional meaning and to insure uniform interpretation. To this end, the following definitions apply:

ACCESS CONTROL: Restriction of access to and from abutting lands to railroad property.

AREMA: American Railroad Engineering and Maintenance of Way Association.

ANSI: American National Standard Institute.

ASTM: American Society for Testing and Materials.

BACKFILL: Replacement of soil around and over an underground utility facility.

BORING: Piercing a hole under the surface of the ground without disturbing the earth surrounding the hole. Boring may be accomplished by any approved manner. Water jetting or puddling will not be permitted. Holes may be mechanically bored and cased using a cutting head and continuous auger mounted inside of the casing. Small diameter holes may be augured, and the casing or utility facility pushed in later.

BNSF: Burlington Northern and Santa Fe Railway Company.

BURY: Placement of the utility facility below grade of roadway, ditch or natural ground to a specified depth.

CARRIER: Pipe directly enclosing a transmitted fluid (liquid or gas).

CATHODIC PROTECTION: A means of corrosion control for a metal pipeline with an active induced current, or a passive system that could include sacrificial anodes and/or a coating rated for "cathodic protection." Fusion-bonded epoxy (a powder coating) with an abrasion resistant overlay is one example of rated coatings.

CASING: A larger pipe enclosing a carrier.

CFR: Code of Federal Regulations.

COATING: Material applied to or wrapped around a pipe.

COMMUNICATION LINE: Fiber optic, telephone cable and similar lines, not exceeding four hundred (400) volts to ground or seven hundred fifty (750) volts between any two (2) points of the circuit, the transmittal power of which does not exceed one hundred fifty (150) watts.

CONDUIT OR DUCT: An enclosed tubular runway for protecting wires or cables.

COVER: The depth of material placed over a utility. Depth of cover is measured from top of utility casing or carrier pipe (if no casing is required) to the natural ground line or construction line above the utility.

DIRECT BURIAL: Installing a utility underground without encasement, by plowing or trenching. No rail plows will be permitted.

ELECTRIC SUPPLY: Electric light, power supply, and trolley lines, irrespective of voltage used for transmitting a supply of electrical energy.

ENCASEMENT: Structural element surrounding a pipe or cable.

FLEXIBLE PIPE: A plastic, fiberglass, or metallic pipe having a large ratio of diameter to wall thickness that can be deformed without undue stress. Copper or aluminum pipe shall be considered as flexible pipe.

GROUNDING: Connected to the earth or to some extended conducting bodies which are intentionally or accidentally connected with the earth.

GROUT: A cement mortar or slurry of fine sand or clay as conditions govern.

HANDHOLES: Handholes, also known as service boxes or joint pits, are necessary for a fiber optic network route along its length to access the cables at periodic intervals.

HORIZONTAL DIRECTIONAL DRILLING: A steerable trenchless method of installing underground pipes, conduits, and cables in a shallow arc along a prescribed bore path by using a surface launched drilling rig, with minimal impact on the surrounding area.

JACK-AND-BORE: The installation method whereby the leading edge of the jacked pipe is well ahead of the cutting face of the auger bit. The auger is removing waste from inside the pipe as it is being jacked. This method greatly reduces the likelihood of subsidence of granular material during installation.

JACKING: The installation of rigid pipes using hydraulic jacks or rams to push the pipe under the traveled surface of a road, railroad roadbed, or other facility.

LICENSE:

UTILITY LICENSE AGREEMENTS are executed for all utility facilities located on railroad property.

LOADING DISTRICTS: The US is divided into three ice, wind, and temperature loading districts identified as HEAVY, MEDIUM, and LIGHT. The loading districts determine design of supporting structures, span lengths and supported facilities based on radial thickness of ice, horizontal wind pressure and temperature conditions for a particular loading district.

MANHOLE: An opening to an underground utility system which workmen or other may enter for the purpose of maintaining, inspecting, or making installations.

NATURAL GAS PIPELINES:

DISTRIBUTION SYSTEM - A pipeline other than a gathering or transmission line.

SERVICE LINE - A distribution line that transports gas from a common source of supply to a customer meter.

TRANSMISSION SYSTEM - A pipeline other than a gathering line that transports gas from a gathering line or storage facility to a distribution center or storage facility. It operates at a hoop stress of twenty percent (20%) or more of the Specified Minimum Yield Strength.

NORMAL: Crossing at a right angle.

PERMITS:

PERMIT TO BE ON BNSF PROPERTY FOR UTILITY SURVEY is to be executed prior to all survey work on railroad property.

PIPE: A tubular product made as a production item for sale as such. Cylinders formed from plate during fabrication of auxiliary equipment are not pipes as defined here.

PRESSURE: Relative internal pressure in PSI (pounds per square inch) gauge.

PRIVATE LINES: Any privately owned facilities which convey or transmit the commodities outlined under the definition for Utilities but are devoted exclusively to private use.

PUBLIC LINES: Those facilities which convey or transmit the commodities outlined under the definition for Utilities and directly or indirectly serve the public or any part thereof.

RIGHT OF WAY: A general term denoting land, property of interest therein, usually in a strip, acquired for or devoted to railroad transportation purposes.

SEAL: A material placed between the carrier pipe and casing to prevent the intrusion of water, where ends of casing are below the ground surface.

SHOULDER: That portion of the roadbed outside the ballast.

SWITCH AREA: Underground = $45' + X' + 45'$ / Overhead = $300' + X' + 300'$, as shown:

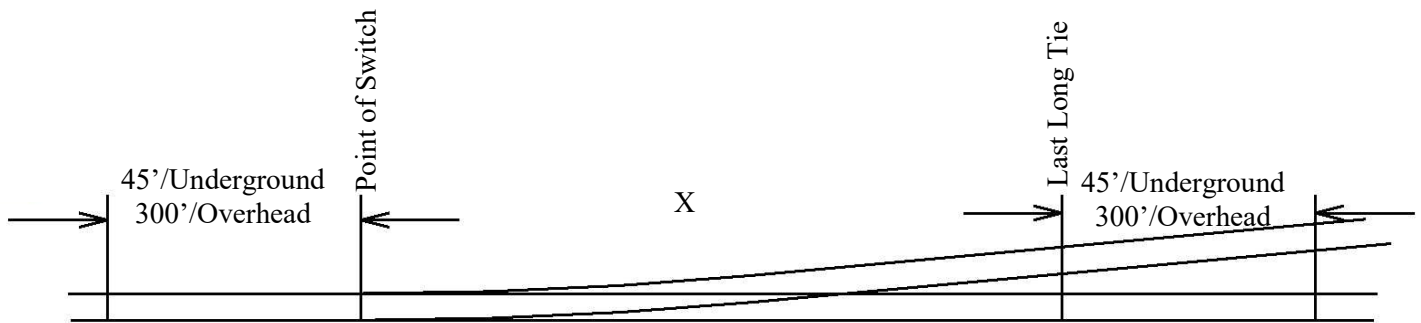

TURNOUT SIZE	X	TURNOUT SIZE	X
NO. 7	95'	NO. 14	176'
NO. 8	98'	NO. 15	180'
NO. 9	107'	NO. 20	249'
NO. 10	120'	NO. 24	283'
NO. 11	125'	NO. 30	632'

TRENCHED: Installed in a narrow excavation.

TUNNELING: Excavating the earth ahead of a large diameter pipe by one or more of the following processes: 1) The earth ahead of the pipe will be excavated by men using hand tools while the pipe is pushed through the holes by means of jacks, rams or other mechanical devices, 2) The excavation is carried on simultaneously with the installation of tunnel liner plates, and/or 3) The tunnel liner plates are installed immediately behind the excavation as it progresses and are assembled completely away from the inside.

UTILITY OWNER: All privately, publicly, or cooperatively owned lines, facilities and systems for producing, transmitting or distributing communications, power, electricity, light, heat, gas, oil, crude products, water, steam, waste, storm water and other similar commodities, including fire and police signal systems and street lighting systems which directly or indirectly serve the public.